



POWER GENERATION SOLENOID AND AIR OPERATED VALVES

Safety Series Features	2
Typical Applications	3
Safety Series Model Numbers	4
Safety Series Dimensional Information	5
Commercial Series Features	6
Commercial Series Model Numbers	7
Warranty and Precautions	8

COMPANY



History

- Located in Novi, Michigan USA, since 1945.
- AV is represented through direct facilities or distribution globally.
- Pneumatic applications include Industrial Automation, Automotive, Process Control, and BWR/CANDU/PWR Power Generation.

QUALITY



Systems

- Automatic Valve quality assurance systems meet requirements of 10CFR50B, ANSI N45.2, and ISO 9001.
- Responsibility for the reportability of defects under 10CFR21 is accepted.

Products

- Commercial products certified to CSA, PTB, and UL standards.
- Safety products qualified for safety related harsh environmental conditions and continuous operation during a LOCA/MSLB/HELB event.
- Safety products environmentally and seismically qualified to IEEE standards 323, 344, and 382 with conduit connections unsealed (per Qual Report 44400R97).

LIFE:	40 YEARS AT 40°C WITH 100% R.H. 10.5 YEARS AT 66°C WITH 100% R.H.
RADIATION:	1.495E8 RADS, GAMMA
CYCLES:	6000
SEISMIC:	AGING @ .75g FROM 5-100-5 Hz OBE @ 3.0g FROM 2-35-2 Hz SSE @ 6.0g FROM 2-100 Hz
ACCIDENT:	100 DAYS INSIDE CONTAIMENT ACCIDENT PROFILE AT 180°C AND 255°C PEAK, CHEMICAL SPRAY AND 100% R.H. FOR 2 CYCLES.

FEATURES



Reliable Design

- Simplicity of the poppet design ensures reliability and ease of maintenance with no diaphragms.
- Mounting installation may be in any position.
- All safety solenoids are certified class H insulation or better, continuous duty, Nema 4 nominal 18 Watt power consumption with voltage suppression diode.
- All safety elastomers are certified fluorocarbon and independently material verified.
- All safety metallics are certified and independently material verified.
- Large free-flow orifices only require 50 micron filtration or better.
- Qualified mounting brackets available separately.

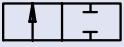
2/2 

3/2 

POWER GENERATION TYPICAL APPLICATIONS

EQ: IEEE 323, 344, 382

FLOW: Cv 0.1 - 35.7

SIZE: 1/4 - 1 1/2 NPTF

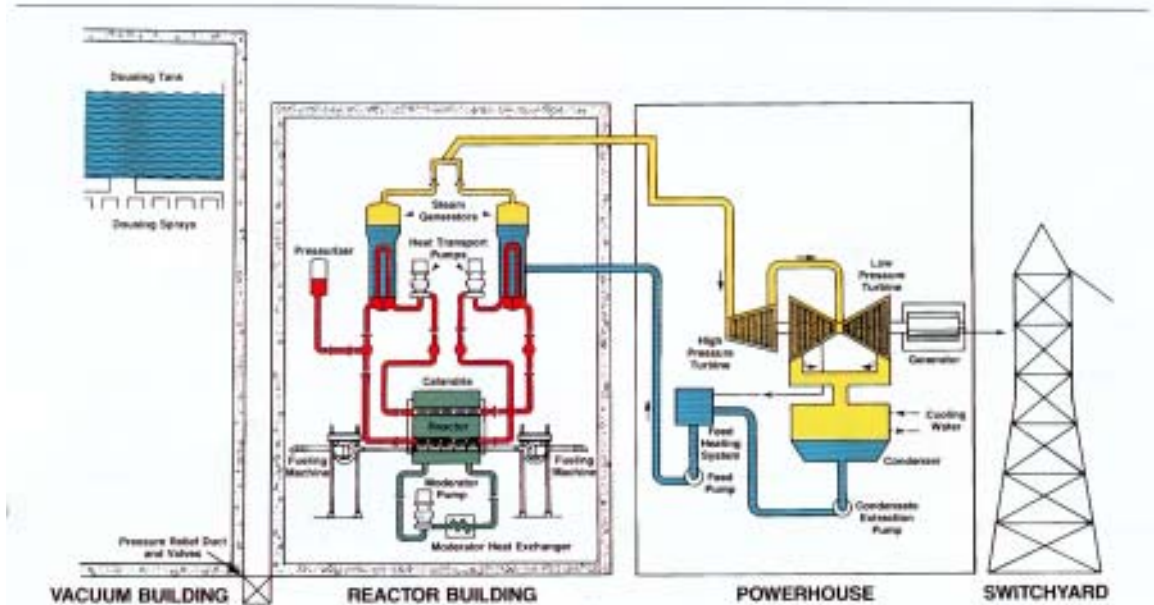
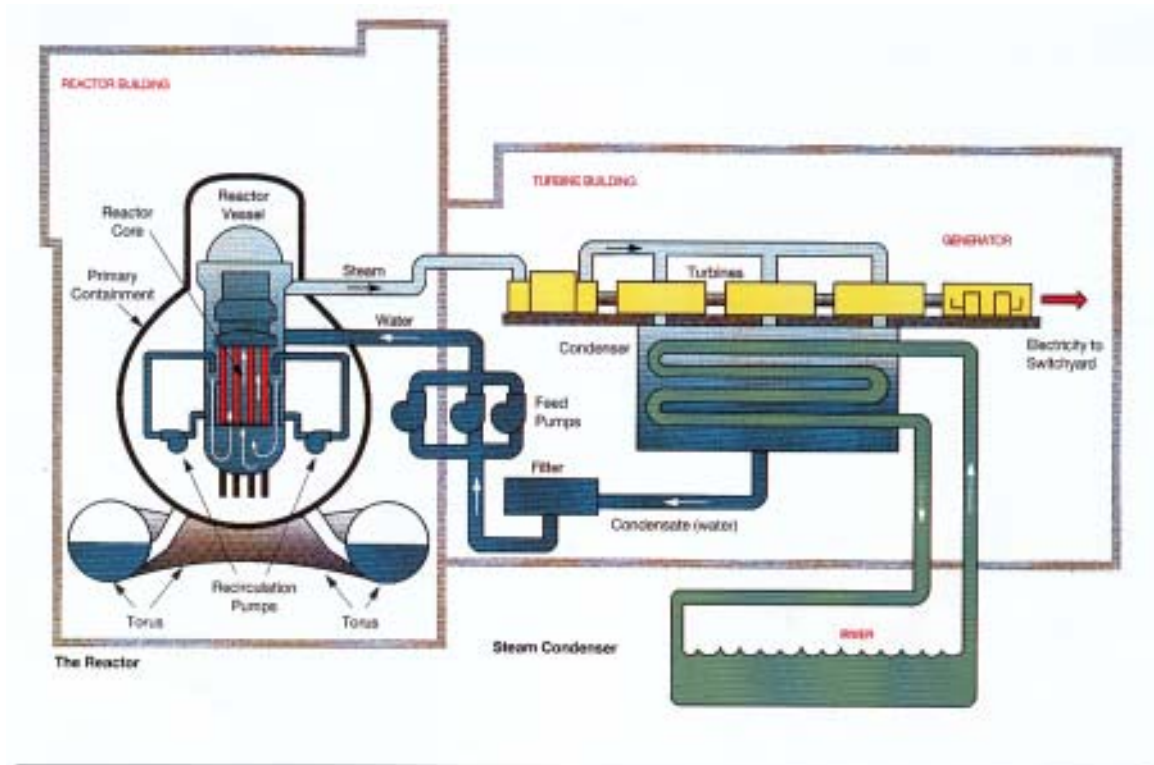

2/2 

3/2 

SAFETY SERIES SPECIFICATION AND MODEL NUMBER INFORMATION

EQ: IEEE 323, 344, 382

FLOW: Cv 0.4 - 35.7

SIZE: 1/4 - 1 1/2 NPTF

SPECIFICATIONS AND MODEL NUMBERS

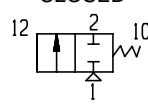
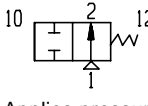
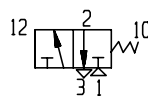
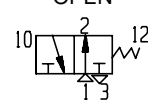
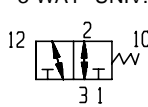
FUNCTION	PORT SIZE NPTF		TYPE	TEMP.		AIR PRESS.		FLOW Cv	MODEL NUMBERS		WT lb/kg	BODY MAT'L	SEAL MAT'L
	1,2	3		F	C	PSIG	kPa		AIR PILOT	SOLENOID			
<p>2 WAY NORMALLY CLOSED</p>  <p>Applies pressure when energized and blocks pressure when de-energized</p>	1/4	-	DIRECT	32-150	0-66	0-125	0-861	0.5	NA	U0203JB**	2.2/1.0	SS	F L U O R O C A R B O N
	1/4	-	PILOT	32-150	0-66	35-150	241-1034	2.5	U0603JBAR	U0603JB**	3.8/1.7	AL	
	3/8	-						3.9	U0604JBAR	U0604JB**			
	1/2	-						5.5	U0605JBAR	U0605JB**			
	1/2	-	PILOT	32-150	0-66	35-150	241-1034	7.6	U1405JBAR	U1405JB**	5.4/2.4	AL	
	3/4	-						11.3	U1406JBAR	U1406JB**			
	1	-						14.8	U1407JBAR	U1407JB**			
	1	-	PILOT	32-150	0-66	35-150	241-1034	29.5	U3607JBAR	U3607JB**	8.1/3.6	AL	
	1 1/4	-						31.8	U3608JBAR	U3608JB**			
	1 1/2	-						35.7	U3609JBAR	U3609JB**			
<p>2 WAY NORMALLY OPEN</p>  <p>Applies pressure when de-energized and blocks pressure when energized</p>	1/4	-	DIRECT	32-150	0-66	0-125	0-861	0.3	NA	U0203KB**	2.2/1.0	SS	F L U O R O C A R B O N
	1/4	-	PILOT	32-150	0-66	35-150	241-1034	2.5	U0603KBAR	U0603KB**	3.8/1.7	AL	
	3/8	-						3.6	U0604KBAR	U0604KB**			
	1/2	-						4.7	U0605KBAR	U0605KB**			
	1/2	-	PILOT	32-150	0-66	35-150	241-1034	5.4	U1405KBAR	U1405KB**	5.1/2.3	AL	
	3/4	-						8.0	U1406KBAR	U1406KB**			
	1	-						9.2	U1407KBAR	U1407KB**			
	1	-	PILOT	32-150	0-66	35-150	241-1034	29.5	U3607KBAR	U3607KB**	8.1/3.6	AL	
	1 1/4	-						31.8	U3608KBAR	U3608KB**			
	1 1/2	-						35.7	U3609KBAR	U3609KB**			
<p>3 WAY NORMALLY CLOSED</p>  <p>Applies pressure when energized and exhausts pressure when de-energized.</p>	1/4	1/4	DIRECT	32-150	0-66	0-125	0-861	0.5	NA	U0203GB**	2.2/1.0	SS	F L U O R O C A R B O N
	1/4	1/2	PILOT	32-150	0-66	35-150	241-1034	2.5	U0603GBAR	U0603GB**	3.8/1.7	AL	
	3/8	1/2						3.9	U0604GBAR	U0604GB**			
	1/2	1/2						5.5	U0605GBAR	U0605GB**			
	1/2	1	PILOT	32-150	0-66	35-150	241-1034	7.6	U1405GBAR	U1405GB**	5.4/2.4	AL	
	3/4	1						11.3	U1406GBAR	U1406GB**			
	1	1						14.8	U1407GBAR	U1407GB**			
	1	1 1/2	PILOT	32-150	0-66	35-150	241-1034	29.5	U3607GBAR	U3607GB**	8.1/3.6	AL	
	1 1/4	1 1/2						31.8	U3608GBAR	U3608GB**			
	1 1/2	1 1/2						35.7	U3609GBAR	U3609GB**			
<p>3 WAY NORMALLY OPEN</p>  <p>Applies pressure when de-energized and exhausts pressure when energized.</p>	1/4	1/4	DIRECT	32-150	0-66	0-125	0-861	0.3	NA	U0203HB**	2.2/1.0	SS	F L U O R O C A R B O N
	1/4	1/2	PILOT	32-150	0-66	35-150	241-1034	2.5	U0603HBAR	U0603HB**	3.8/1.7	AL	
	3/8	1/2						3.6	U0604HBAR	U0604HB**			
	1/2	1/2						4.7	U0605HBAR	U0605HB**			
	1/2	1	PILOT	32-150	0-66	35-150	241-1034	5.4	U1405HBAR	U1405HB**	5.1/2.3	AL	
	3/4	1						8.0	U1406HBAR	U1406HB**			
	1	1						9.2	U1407HBAR	U1407HB**			
	1	1 1/2	PILOT	32-150	0-66	35-150	241-1034	29.5	U3607HBAR	U3607HB**	8.1/3.6	AL	
	1 1/4	1 1/2						31.8	U3608HBAR	U3608HB**			
	1 1/2	1 1/2						35.7	U3609HBAR	U3609HB**			
<p>3-WAY UNIV.</p>  <p>May be used for NC or NO oper.</p>	1/4	1/4	DIRECT	32-150	0-66	0-125	0-861	0.3	NA	U0203FB**	2.2/1.0	SS	F L U O R O C A R B O N

ELECTRICAL CHARACTERISTICS

VOLTAGE CODE **	CONTINUOUS DUTY		WATTAG	CURRENT AMPS		RESISTANCE OHMS 20°C
	NOMINAL	RANGE		HOLDING	INRUSH	
AA	120VAC	90-140	18	.32	.59	40
DC	48VDC	35-56	16	.33	.33	148
DE	125VDC	90-144	16	.13	.13	948
DD	250VDC	180-288	16	.06	.06	3758

2/2

3/2

SAFETY SERIES DIMENSIONAL INFORMATION

EQ: IEEE 323, 344, 382

FLOW: Cv 0.1 - 35.7

SIZE: 1/4 - 1 1/2 NPTF

AIR PILOT OPERATED - SERIES U06, U14, & U36

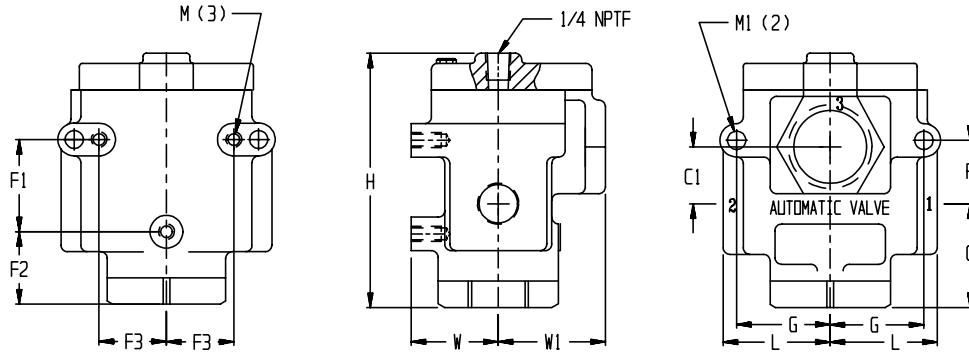

SOLENOID OPERATED SERIES U02

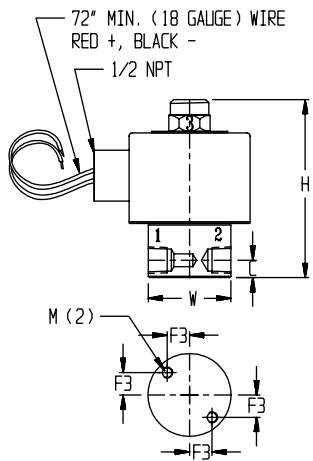

SOLENOID OPERATED - SERIES U06, U14 & U36

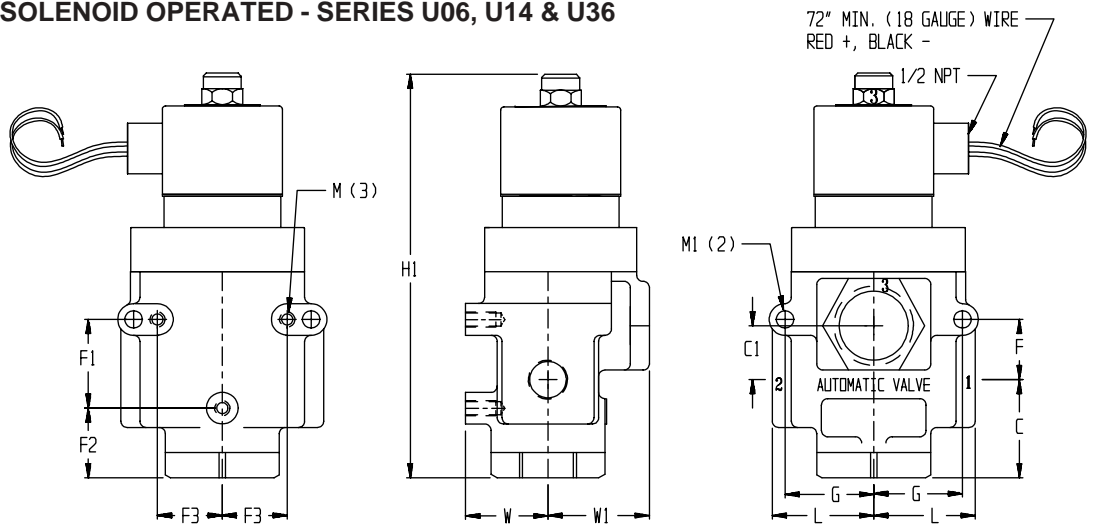

DIMENSIONS MM/INCHES

SERIES	MODEL	C	C1	F	F1	F2	F3	G	H	H1	L	M	M1	W	W1
U02	ALL	8,7 .34	-	-	-	-	11,2 .44	-	98,6 3.88	-	-	#10- 32	-	41,3 1.63	-
U06	NORMALLY CLOSED	32,5 1.28	20,6 .81	20,6 .81	42,9 1.68	17,4 .68	25,4 1.00	37,3 1.47	91,3 3.59	172 6.77	41,3 1.62	1/4- 20	7,1 .28	33,3 1.31	44,5 1.75
	NORMALLY OPEN	20,6 .81	27,0 1.06	29,5 1.16	42,9 1.68	7,14 .28	25,4 1.00	37,3 1.47	85,8 3.38	166 6.55	41,3 1.62	1/4- 20	7,1 .28	33,3 1.31	44,5 1.75
U14	NORMALLY CLOSED	49,3 1.94	27,0 1.06	30,2 1.19	44,5 1.75	34,9 1.37	33,3 1.31	44,5 1.75	121 4.75	202 7.94	50,8 2.00	5/16- 18	8,7 .34	41,3 1.62	50,8 2.00
	NORMALLY OPEN	22,1 .87	27,0 1.06	-	44,5 1.75	7,9 .31	33,3 1.31	-	105 4.13	186 7.31	50,8 2.00	5/16- 18	-	41,3 1.62	50,8 2.00
U36	NORMALLY CLOSED	67,5 2.66	50,8 2.00	76,2 3.00	100 3.94	43,7 1.72	41,3 1.62	-	184 7.25	269 10.59	76,2 3.00	3/8- 16	-	60,5 2.38	79,2 3.12
	NORMALLY OPEN	35,1 1.38	50,8 2.00	-	100 3.94	11,1 .44	41,3 1.62	-	165 6.50	248 9.75	76,2 3.00	3/8- 16	-	60,5 2.38	79,2 3.12

FLOW DIAGRAMS

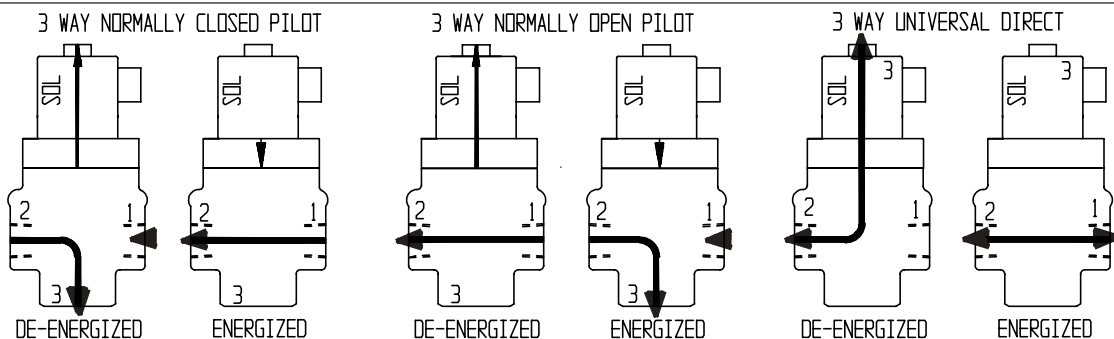

Features

Tapered Tee Seal.... Eats Dirt

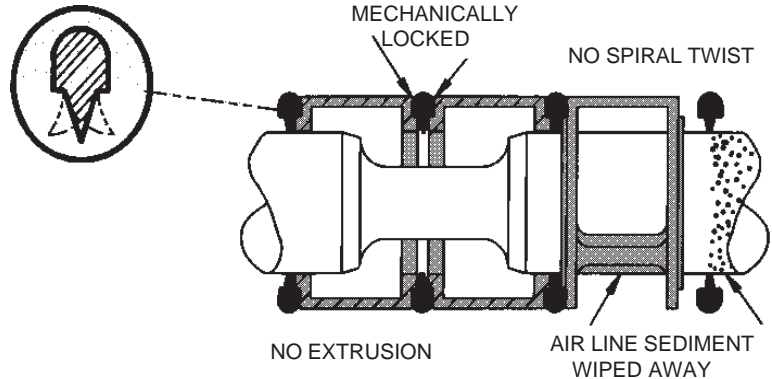

- Bi-Directional tapered Tee Seal lip flexes to clean spool, **Eliminates Monday morning sticking problems.**

- Tested tough and proven reliable according to SAE specifications.
 - Rust and water injected every 864,000 cycles for 20 million cycles.
- Available for use in both air and vacuum service.
- 50 Micron filtration is all that is needed..... **NO need to buy 2-5 micron filters.**
- Molded from superior, tough, Carboxylated Nitrile. Provides five times the abrasion resistance and service life of Buna-n-seals.

Solenoid....

Guaranteed against burnout



- Three-way pilot uses full air line pressure to shift the valve spool.
- Pilot is internally supplied when the pressure at port 1 is 35 to 150 psig (2 to 10 bar).
- Coil is hermetically sealed as an integral watertight molded unit.
- Standard temperature ranges equal or exceed competitors "High Temperature" options.
- Intrinsically-safe and explosion-proof versions available.



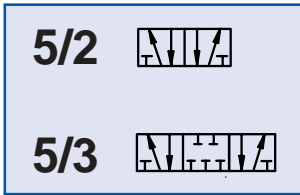

COMMERCIAL SERIES DIMENSION, SPECIFICATION, MODEL NUMBER INFORMATION

FLOW: Cv 1.8 (L20)
Cv 4.5 (L45)

SIZE : 1/4 NPTF (L20)
1/2 NPTF (L45)

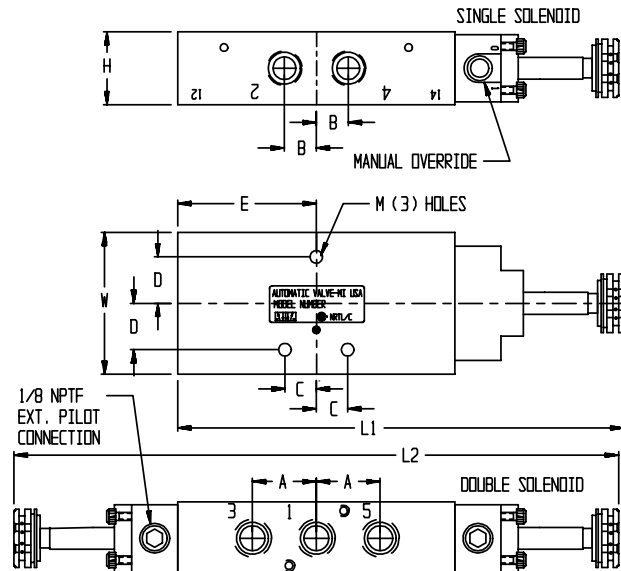

DIMENSIONS MM/INCHES

SERIES	A	B	C	D	H	L1	L2	M	W
L20	22,2 .88	11,1 .44	10,9 .43	16,1 .64	25,4 1.00	156 6.15	216 8.50	4,4 .17	49,0 1.94
L45	31,8 1.25	15,9 .63	15,1 .59	23,8 .94	31,8 1.25	206 8.10	273 10.7	6,7 .27	63,5 2.50

FIELD CONVERSION	PLUG	SUPPLY	OUTLET	EXHAUST
2-WAY NORMALLY CLOSED	2,3,5	1	4	-
2-WAY NORMALLY OPEN	4,3,5	1	2	-
3-WAY NORMALLY CLOSED	2,3	1	4	5
3-WAY NORMALLY OPEN	4,5	1	2	3
3-WAY DIVERTER	3,5	1	2,4	-
3-WAY SELECTOR	3,5	2,4	1	-
4-WAY	-	1	2,4	3,5
4-WAY DUAL PRESSURE	-	3,5	2,4	1

* Minimum operating pressure is 35 psi. Use external pilot when using a port other than 1 for supply or when using a fluid media besides air.

SPECIFICATIONS

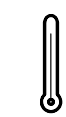

SOLENOID- STANDARD: -20°F + 150°F (-30°C + 66°C)

AIR PILOT - STANDARD: -20°F + 150°F (-30°C + 66°C)



NOT REQUIRED BUT RECOMMENDED TO MAXIMIZE SERVICE LIFE



50 MICRON OR BETTER.



SOLENOID- STANDARD: 35 - 150 PSIG (2 - 10 BAR)

EXT PILOT: 29" Hg VAC - 150 PSIG (0 - 10 BAR)

AIR PILOT- 29" Hg VAC - 150 PSIG (0 - 10 BAR)

MANUAL - 29" Hg VAC - 150 PSIG (0 - 10 BAR)

PILOT PORT

INTERNAL

35 - 150 PSIG (2 - 10 BAR)

35 - 150 PSIG (2 - 10 BAR)

NONE

PART NUMBERS AND ELECTRICAL INFORMATION

VALVE LESS W COIL		PART NO.*	Kg/Lb
	SINGLE SOLENOID	L20	L2003AAWR .32/1.7
		L45	L4505AAWR .63/1.4
	DOUBLE SOLENOID	L20	L2003ABWW .36/1.8
		L45	L4505ABWW .72/1.6
KITS			
	AIR PILOT - 1/8" CONNECTION	L20	A7106-352 .06
		L45	A7106-352 .14
	Y EXPLOSIONPROOF - NEMA 4/7/9 1/2" CONNECTION	L20	A7106-391.** .36
		L45	A7106-391.** .80
	3 POSITION PISTONS AND C SPOOL (BLOCKED)	L20	A8022-634 .05/1
		L45	A7128-094 .14/3
	3 POSITION PISTONS AND D SPOOL (EXHAUST)	L20	A8022-635 .05/1
		L45	A7128-095 .09/2
	3 POSITION PISTONS AND E SPOOL (PRESSURE)	L20	A8022-636 .05/1
		L45	A7128-096 .09/2

ACCESSORIES	PART NO.*	Kg/Lb
W COIL - 1/2" CONDUIT CONNECTION	7019-9**C	.01 .03
W COIL - LEAD WIRE CONNECTION	7019-9**G	
W COIL - NEMA 4X/IP65 DIN CONNECTION	7019-9**	.06 .13
DIN CONNECTOR - 6' CORD	7020-006	
DIN CONNECTOR - 6' CORD LIGHTED < 48V	A7094-007	
DIN CONNECTOR - 6' CORD LIGHTED > 48V	A7094-006	
ADAPTOR FOR Y EXPLOSIONPROOF	A8022-689	

VOLTAGE ±10% CONTINUOUS DUTY	C O D E	CURRENT (AMPS)				RESIST. OHMS		POWER WATTS	
		INRUSH		HOLDING		OHMS		WATTS	
		W	Y	W	Y	W	Y	W	Y
22/50 24/60	DA	.40	.55	.40	.32	31.6	19	4.8	6
110/50 120/60	AA	.08	.13	.06	.06	840	475	4.8	6
220/50 240/60	AB	.04	.05	.03	.03	3400	2000	4.8	6
12 VDC	DA	.40	.60	.40	.60	31.6	19	4.8	7
24 VDC	DB	.20	.30	.20	.30	121	75	4.8	7
125 VDC	AB	.04	.06	.04	.06	3400	2000	4.8	7

CONSULT FACTORY FOR MANUAL OPERATORS, MANIFOLDS, OR ADDITIONAL ACCESSORIES. * SOLD IN MULTIPLES OF (5).





AUTOMATIC VALVE
41144 Vincenti Court Novi MI USA 48375-1922
Internet Address www.automaticvalve.com
Telephone 248.474.6700 Facsimile 248.474.6732
World Class Air Valves and Controls

WARRANTY

AUTOMATIC VALVE WARRANTS ITS PRODUCTS TO BE FREE FROM DEFECTS IN MATERIAL OR WORKMANSHIP OVER A PERIOD OF 18 MONTHS FROM THE DATE OF SHIPMENT FROM ITS FACTORY. AUTOMATIC VALVE WILL, AT ITS OPTIONS, EITHER REPAIR OR REPLACE THE ALLEGEDLY NON-CONFORMING PRODUCT AT NO CHARGE, FOB OUR FACTORY, UPON RETURN OF THE PRODUCT WITH TRANSPORTATION PREPAID.

AUTOMATIC VALVE WILL REPLACE STANDARD COMMERCIAL NEMA 4 SOLENOID COILS WHICH FAIL DUE TO BURNOUT WHEN OPERATED WITHIN THEIR RATED CAPACITY OR VOLTAGE.

AUTOMATIC VALVE IS NOT RESPONSIBLE FOR DAMAGE TO ITS PRODUCTS THROUGH IMPROPER INSTALLATION, MAINTENANCE, USE, REPAIRS, OR OPERATING BEYOND RATED CAPACITY OF VOLTAGE, INTENTIONAL OR OTHERWISE. AUTOMATIC VALVE IS NOT LIABLE FOR CLAIMS FOR LABOR, LOSS OF PROFIT OR GOOD WILL, REPAIRS, DELAY DAMAGES, DIRECT OR INDIRECT PENALTIES, OR EXPENSES INCIDENTAL TO REPLACEMENT. THE BUYER, BY ACCEPTANCE OF DELIVERY, ASSUMES ALL LIABILITY FOR THE PRODUCT'S USE OR MISUSE IN THE AS-SHIPPED CONDITION.

NO OTHER REPRESENTATIONS, GUARANTEES, OR WARRANTIES, EXPRESS OR IMPLIED, ARE MADE BY AUTOMATIC VALVE AND THE FOREGOING LIMITED WARRANTY IS IN LIEU OF ALL OTHER REPRESENTATIONS AND WARRANTIES, EXPRESS OR IMPLIED, WHICH ARE HEREBY EXPRESSLY DISCLAIMED AND WAIVED BY THE BUYER, INCLUDING ANY WARRANTY OF MERCHANTABILITY OR FITNESS FOR PARTICULAR PURPOSE.

AUTOMATIC VALVE, RECOGNIZING ITS GOAL OF CONTINUOUS IMPROVEMENT, RESERVES THE RIGHT TO DISCONTINUE OR CHANGE SPECIFICATIONS, PRODUCTS, OR PRICES WITHOUT INCURRING OBLIGATION.

PRECAUTIONS

APPLICATION: AUTOMATIC VALVES ARE GENERAL PURPOSE, INDUSTRIAL PNEUMATIC AND VACUUM SERVICE VALVES. THEY ARE NOT THEMSELVES INHERENTLY HARMFUL; HOWEVER, THE CONTROL SYSTEMS IN WHICH THEY OPERATE MUST HAVE NECESSARY SAFEGUARDS TO PREVENT DAMAGE OR INJURY SHOULD FAILURE OF THE SYSTEM COMPONENTS OCCUR.

OSHA REGULATION 1910.217, DATED NOVEMBER 1, 1975, AND ANSI STANDARD B11.1, 1971, REVISION 1982, SPECIFICALLY RECOMMENDED SPECIAL PURPOSE DUAL (DOUBLE) SAFETY CLUTCH AND BRAKE VALVES FOR POWER PRESSES. AUTOMATIC VALVE DOES NOT MANUFACTURE SPECIAL PURPOSE DUAL SAFETY VALVES FOR PRESSES. DO NOT USE AUTOMATIC VALVES FOR POWER PRESSES.

TWO POSITION AUTOMATIC VALVES, WHETHER THEY ARE 2-WAY, 3-WAY, OR 4-WAY, WILL ALWAYS HAVE A FLOW PATH FROM THE VALVE'S INLET PORT OR PORTS TO ONE OF THE OUTLETS, REGARDLESS OF WHICH OF THE TWO POSITIONS IS USED. IF AIR TRAPPED IN OR EXHAUSTED FROM THE PORTS PRESENTS A HAZARD IN OPERATION OR IN SERVICING THE SYSTEM, A SEPARATE METHOD MUST BE PROVIDED TO EXHAUST THIS AIR OR THE VALVE SHOULD NOT BE USED.

THREE POSITION 3-WAY AND 4-WAY AUTOMATIC VALVES, WHETHER SOLENOID OPERATED, AIR PILOTED, OR MANUALLY OPERATED, CAN MOVE TO THE CENTER POSITION IF THE OPERATORS ARE NOT ACTUATED. IF AIR TRAPPED IN OR EXHAUSTED FROM THE PORTS PRESENTS A HAZARD IN OPERATION OR IN SERVICING THE SYSTEM, A SEPARATE METHOD MUST BE PROVIDED TO EXHAUST THIS AIR OR THE VALVE SHOULD NOT BE USED.

SOME SOLENOID AND AIR PILOTED AUTOMATIC VALVES INCORPORATE MANUAL OVERRIDES. MANUAL OVERRIDES, WHEN ACTUATED, SHIFT THE VALVE AS IF THE SOLENOID OR AIR PILOT WERE ACTUATED, IF ACCIDENTAL OR INTENTIONAL OPERATION OF THE MANUAL OVERRIDE COULD CAUSE A DANGEROUS PROBLEM, VALVES WITHOUT A MANUAL OVERRIDE SHOULD BE USED.

USE AUTOMATIC VALVES ONLY WITHIN SPECIFICATION LIMITS LISTED IN OUR CATALOG.

INSTALLATION: CONSULT THE ENGINEERING AND MAINTENANCE SECTION OF THE AUTOMATIC VALVE CATALOG FOR INSTALLATION INSTRUCTIONS. DO NOT INSTALL AUTOMATIC VALVES WITHOUT FIRST TURNING OFF AIR AND ELECTRICITY. AUTOMATIC VALVES MUST BE INSTALLED BY QUALIFIED AND KNOWLEDGEABLE PERSONNEL WHO UNDERSTAND HOW SPECIFIC VALVES ARE TO BE PIPED AND ELECTRICALLY CONNECTED. DO NOT INSTALL VALVES UNLESS THE VALVE'S FLOW PATH, AS DESCRIBED BY ANSI & ISO SYMBOLS IN OUR CATALOG, CONFORMS TO THE APPLICATION'S DESIGN SPECIFICATIONS.

MAINTENANCE: DISCONNECT AIR AND ELECTRICITY AND BLEED ALL PRESSURIZED CYLINDER LINES BEFORE REMOVING TWO AND THREE POSITION AUTOMATIC VALVES. CONSULT THE ENGINEERING AND MAINTENANCE SECTION OF THE AUTOMATIC VALVE CATALOG FOR MAINTENANCE INSTRUCTIONS. AUTOMATIC VALVES MUST BE SERVICED BY QUALIFIED AND KNOWLEDGEABLE PERSONNEL WHO UNDERSTAND THE FUNCTION AND OPERATION OF SPECIFIC VALVES. CARE MUST BE FOLLOWED TO PREVENT DAMAGE TO VALVES CAUSED BY STEPPING ON THEM, DROPPING THEM, OR HITTING THEM WITH ANY OBJECT. DAMAGED VALVES SHOULD BE RETURNED TO AUTOMATIC VALVE FOR INSPECTION AND REBUILDING.



Access our Home Page on the World
Wide Web for more information about....

- Company Profile
- Catalogs
- New Products
- Service
- Local Stocking Distributors

or e-mail us: avc@automaticvalve.com